

Technical Note
n.6001
January 2008

Technical description
B2C distribution of video content via IP network by means of MPEG-2 Transport Stream (TS) feeding an AXMEDIS compliant Set Top Box (STB) for viewing video on TV

Description of Content

Trial video clips of VRS authored funny home videos with embedded video ads, formatted as AXMEDIS objects with MPEG 2 video content, specially processed for MPEG TS video with accompanying information. The objects are streamed to trial IPTV service user's STB's.

Business Model

Revenue from content distribution to consumers could be earned based on three basic models:

- Advertiser pays to the distributor for ads shown to consumers;
- Consumer pays to the distributor for paid content; or
- A combination of the two.

VIDEO on demand distribution for IPTV digital set-top-box

As part of AXMEDIS, a group of partners from Baltic States has undertaken to deploy a video-on-demand distribution solution based on AXMEDIS Framework. The real life demonstration prototype involves a video content producer from Lithuania (VRS Grupe), and two broadband operators – ELION (Estonia), operating an internet-based media distribution portal, and TEO (Lithuania) – IPTV service provider. Although the purpose of the trial is to show how AXMEDIS solutions and tools can be used in an integrated automatic content production and distribution value chain, this technical note describes the technical aspects of the TEO platform, integrating AXMEDIS tools into IPTV video on demand (VOD) service.

The purpose of TEO trial is to showcase AXMEDIS technology adopted for IPTV platform. It demonstrates broadband operator's distribution of video on demand (VOD) content to trial IPTV service subscribers. IPTV service subscribers can view digital video material on their TV through an AXMEDIS compliant Set Top Box (STB).

TEO IPTV AXMEDIS system architecture

High level description

The scheme below depicts the general components of the integrated TEO trial. Components depicted in yellow background are software components developed by the above mentioned partners specifically for this IPTV STB solution.

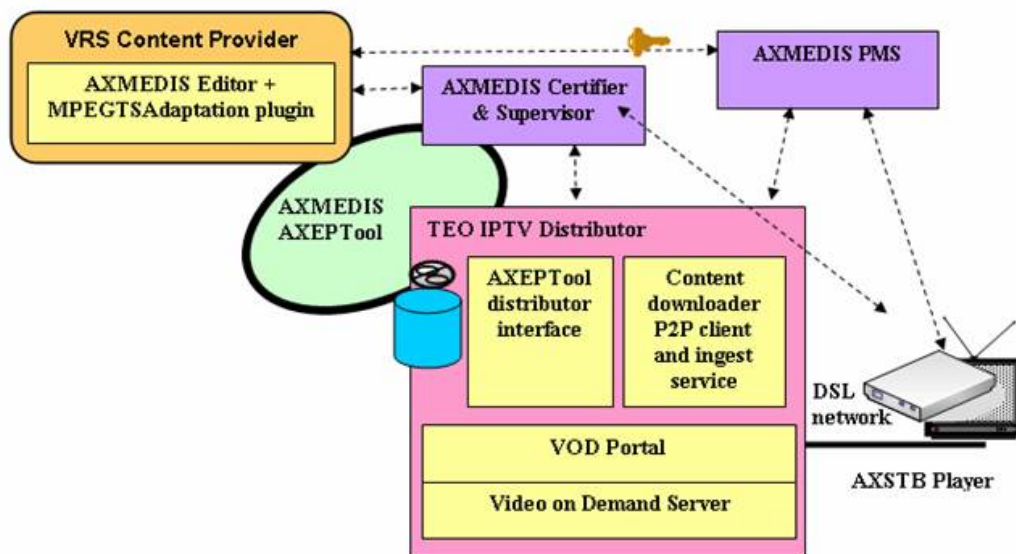

For this solution, of B2B automatic content production and distribution for IPTV, the content producer VRS uses AXCP http://www.axmedis.org/documenti/view_documenti.php?doc_id=3624 and an AXMEDIS MPEG TS Adaptation Plugin to produce and make available trial video content in AXMEDIS MPEG-21 format for TEO IPTV service. The videos are formatted as AXMEDIS Objects, with pre-set usage rights and conditions and defined metadata. VRS places these AXMEDIS Objects into P2P network by using the AXEPTool http://www.axmedis.org/documenti/view_documenti.php?doc_id=3612. TEO IPTV distribution facility downloads the AXMEDIS objects from the P2P by using content downloader P2P AXEPTool client and ingest service and place them into VOD portal and server which includes also Customer relationship manager and content management system. The VOD server it is capable to stream the content on demand to the users' STB.

Detailed system description

TEO IPTV AXMEDIS setup is based on existing TEO Gala IPTV infrastructure. It started using existing IPTV architecture components in addition with some newly developed components (depicted in light blue) integrating AXMEDIS DRM elements and AXMEDIS content production and player tools.

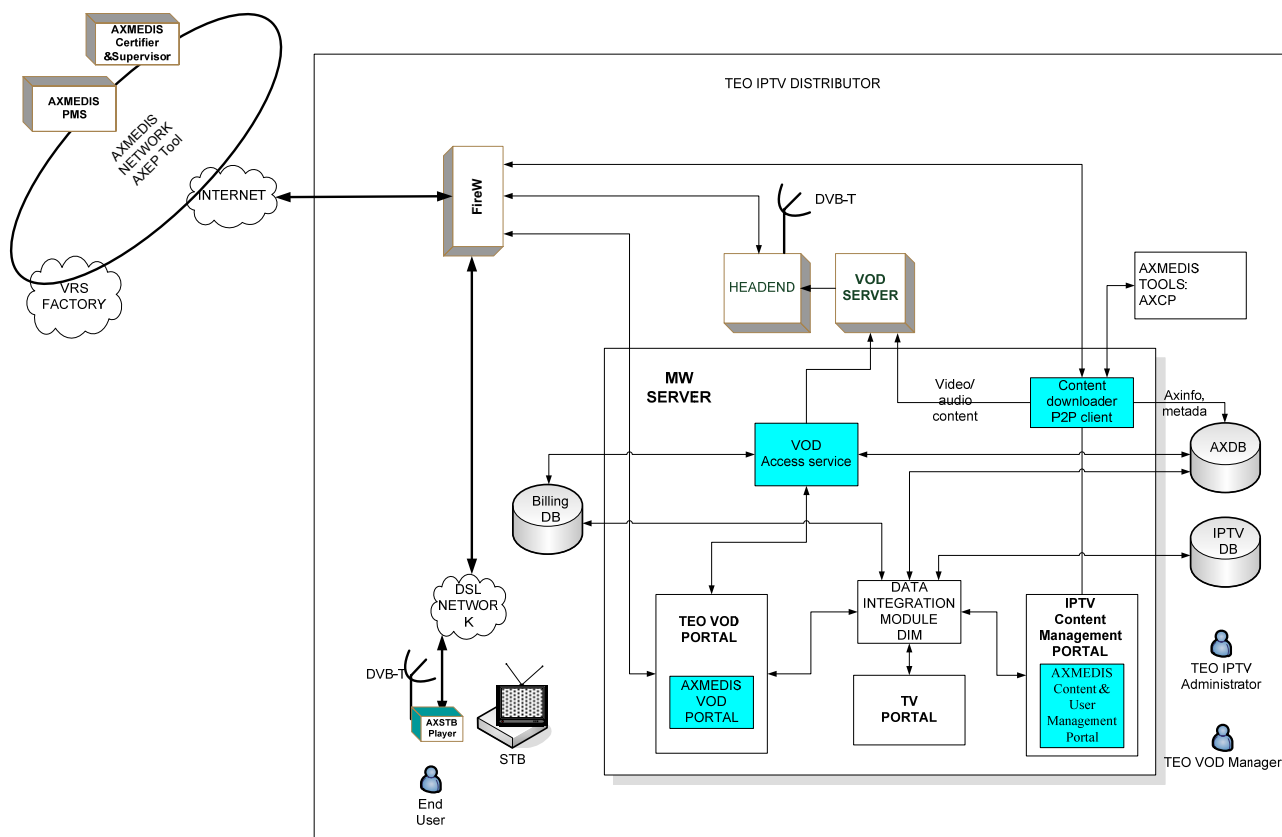

TEO IPTV AXMEDIS trial is comprised of:

- **MiddleWare Server** and related components, as follows:

- Existing TEO Gala IPTV database IPTV DB. In this DB information about clients, services and accounting information are stored. Communication with IPTV DB is performed using DIM-ADO.NET.
- Existing Billing DB database, where TEO users billing information is stored. Communication with this DB is performed using WebServices.
- In AXDB the AXMEDIS object metadata and stream information (AxStreamResource) are stored. The MPEG-2 TS resources are excluded due to storage efficiency. This DB is based on AXMEDIS database.
- Data integration module (DIM) is an additional solution for integration different data formats in databases.
- TV Portal – TEO portal for Gala TV IPTV services:
 - On-line TV channels;
 - Electronic program guide, EPG;
 - Gaming, etc.;
- AXMEDIS VOD Portal, based on TEO Middleware platform. This portal is used to present AXMEDIS content for End User. AXSTB Player uses this portal to retrieve information about content and usage information.
- AXMEDIS Content & User Management Portal, which has been developed on IPTV Content Management Portal platform and used for TEO AXMEDIS content and user management. This module has been implemented in IPTV Content Management Portal and used by TEO VOD Manager and TEO IPTV Administrator.

- VOD Access Service – a component developed for TEO IPTV setup. This component is responsible for proper End User AXSTB Player connection with used DB's and services. VOD Access Service communicates with VOD server, Billing DB, IPTV DB, AXDB and AXMEDIS PMS to present required information to End Users and react to End User actions.
 - AXEPTool B2B tool is used for connecting Middleware server with AXMEDIS network and downloading AXMEDIS data from it. http://www.axmedis.org/documenti/view_documenti.php?doc_id=3624
 - Content Downloader P2P client is a newly developed component for placing downloaded AXMEDIS object to VOD server, updating AXMEDIS object metadata and placing metadata and stream information into AXDB. Content downloader P2P client uses AXCP for automatically downloading new objects designed for TEO demonstrator. This component is a part of AXMEDIS Content & User Management Portal and is used by TEO VOD Manager for content management purposes.
- **VOD Server** – VOD content storage server. VOD Server is compatible with existing GALA TV network resources (Kreatel Application platform). The VOD server is capable of streaming DVB-CSA encrypted streams.
 - **Headend Server** – IPTV content distribution and broadcasting server, used for transferring MPEG-2 designated content via TCP/IP network.
 - **AXSTB Player** – based on AXMEDIS module called AXOM, which was integrated into Kreatel STB. AXSTB Player communicates with VOD Server, content and user databases, AXMEDIS PMS Server through VOD Access Service. The AXSTB player is certified and associated to the End User by using AXMEDIS tools and services.



How does the TEO prototype work?

The videos, in AXMEDIS file format, can be manually or automatically downloaded from the AXEPTool (P2P file sharing system), on the video on demand, VOD, server by the VOD content manager operator. The AXMEDIS objects, are based on MPEG-21 standard, and are specific files with embedded video resources and metadata. They can only be viewed through a specially developed AXSTB Player, and/or on any AXMEDIS player. The AXSTB contains a low-footprint client specifically designed to support MPEG-2 video transport stream.

The AXMEDIS objects with videos are made available for viewer's purchasing and viewing on AXMEDIS VOD portal accessible to the user on television. An IPTV service subscriber access to the VOD portal from the STB and thus to the AXMEDIS content category and may decide to view a video from this service.

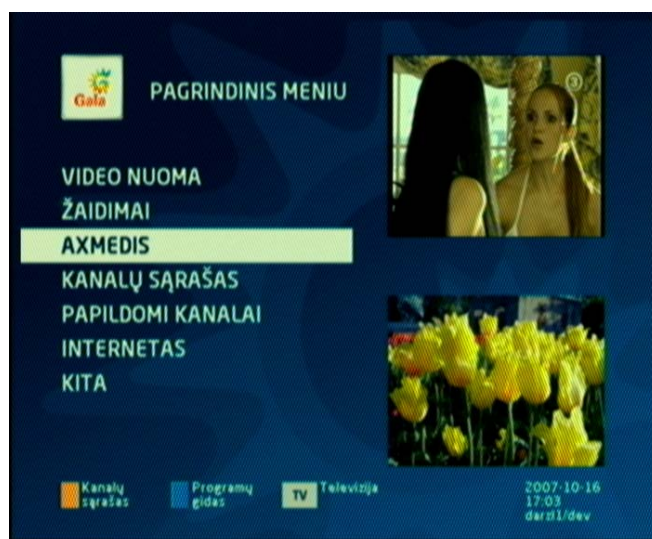

When the user wants to view AXMEDIS digital objects, he/she chooses "AXMEDIS" button and connects to TEO VOD Portal. Using the remote control, the user is connected through an STB to IPTV network to browse through local AXMEDIS Database and select objects for viewing, to get them on demand.

In order to view the content, the End User must obtain a license from the AXMEDIS DRM (AXMEDIS PMS



and AXCS tools (http://www.axmedis.org/documenti/view_documenti.php?doc_id=3616). In the first step, the AXSTB Player verifies the user ID while the AXMEDIS DRM solution ensures digital rights management and content protection. To this end, the developed VOD Portal service displays on the User's TV screen the billing information and simple license conditions for the selected AXMEDIS object (e.g., paid or free, and pricing). If the viewer decides to view protected content, the user is prompted to enter a PIN, which has been received by the user when signed the contract for the IPTV service. Upon the user entering the PIN, AXSTB Player initializes the license generation process, by sending a request to a VOD Access Service. The VOD Access Service interacts with the AXMEDIS PMS server to generate the specific user license. The production of the license allows the AXOM to Grant the Authorization to unprotect the content via the AXOM module of the AXSTB Player.

AXMEDIS STB Player starts to play the selected Video content. All user actions with regards to this content are registered in AXMEDIS Supervisor and Certifier Database.

The user can "Play", "Stop", "Pause", "Fast forward", "Rewind" and perform other remote control actions with this content within the capabilities of VOD server functionality.

The system allows the distributors and the content producers to access information about the user's statistics from the provider's VOD Portal. On the same line the final user can view all information about the number and type of AXMEDIS objects viewed as well as billing information.

After viewing the video clip, the viewer can go back to AXMEDIS browser or can go to IPTV provider's portal home page by pressing http://www.axmedis.org/com/index.php?option=com_frontpage&Itemid=1ing remote control button or by selecting "Home" button on TV screen.

To test the IPTV of TEO you can go on the WEB page and follow the instructions:

http://www.axmedis.org/com/index.php?option=com_content&task=view&id=72&Itemid=51

To see a Video of TEO trial you can download from:

http://www.axmedis.org/documenti/view_documenti.php?doc_id=3604

or simply go on the main page of AXMEDIS:

http://www.axmedis.org/com/index.php?option=com_frontpage&Itemid=1

Description of use cases and scenarios

There are three actors in TEO IPTV AXMEDIS system:

- End Users;
- IPTV provider's System Administrator and
- IPTV provider's VOD Manager

On the content producer's (VRS) side, there is one actor – VRS Content Editor.

The End User uses STB with AXSTB Player and can connect to IPTV network for watching AXMEDIS video content. The End User interface allows browsing through local AXDB and playing selected objects. If selected object is chargeable, End User is prompted to enter his PIN and choose the payment method. End User interface also allows browsing through global AXMEDIS network and viewing object descriptions. End Users can select objects in global AXMEDIS network and subscribe them, but this feature has not been implemented in TEO trial. The End User can view his usage and billing information by using the AXSTB Player.

TEO VOD Manager is responsible for content management in TEO AXMEDIS IPTV network. This actor downloads AXMEDIS objects from global P2P AXMEDIS network and prepares them for streaming in VOD server. TEO VOD Manager downloads objects according to End Users requests or to the business plan.

TEO IPTV Administrator is responsible for user management and can add, delete, and modify user.

VRS Producer is responsible for content production for TEO and Elion demonstrators. For TEO demonstrator VRS Producer creates streaming video AXMEDIS objects, for Elion demonstrator – AXMEDIS objects for PC platform.



End user actions on AXSTB Player

The End User can:

- connect to TEO IPTV network;
- browse and see metadata of AXMEDIS video content (if video object has a trailer, user can watch it for free);
- buy and play AXMEDIS video content (before object playing license must be generated (EU6.)):
 - o enter PIN;
 - o choose payment method;
 - o stop playing video;
 - o pause video;
 - o continue playing;
 - o seek to desired point of video;
- view user information:
 - o view usage information;
 - o view billing information.

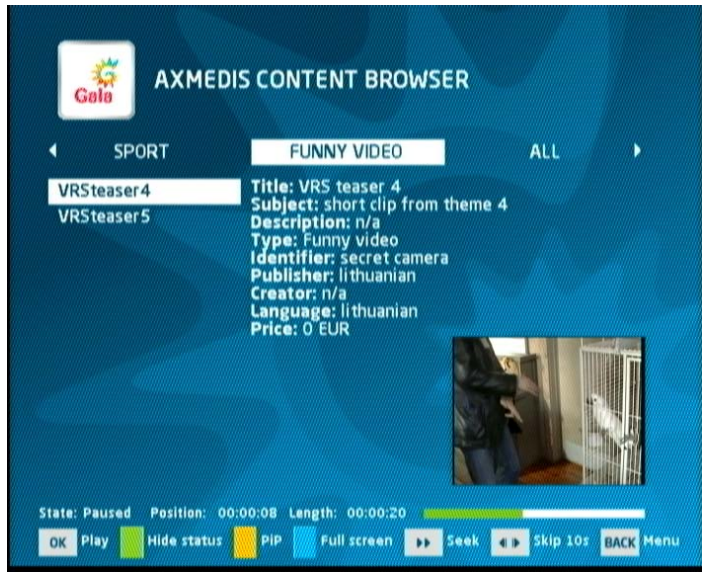

VOD manager actions

The TEO VOD Manager can:

- Connect to TEO Content & User Management Portal;
- Manage TEO AXMEDIS content:
 - o Download AXMEDIS content from global AXMEDIS DB, using AXEPTool and place into VOD Server and AXDB;
 - o Delete content from local TEO AXDB;
 - o Make and view reports about usage of AXMEDIS content in TEO IPTV network.

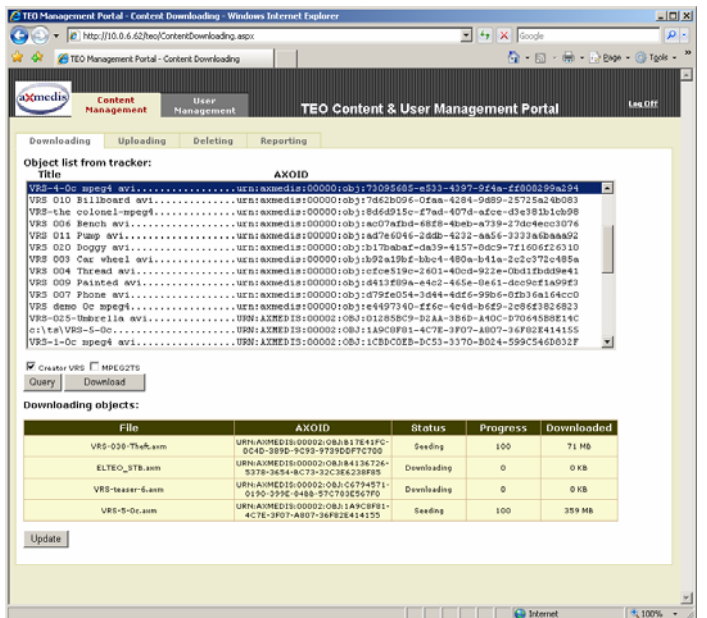

IPTV administrator actions

The TEO IPTV Administrator can:

- Connect to TEO Content & User Management Portal;
- Manage TEO AXMEDIS users:
 - o Add user to TEO AXMEDIS DB;
 - o Delete user from TEO AXMEDIS DB;
 - o Set user rights to use AXMEDIS content in TEO IPTV network;
 - o Make and view reports about user actions in TEO AXMEDIS DB.

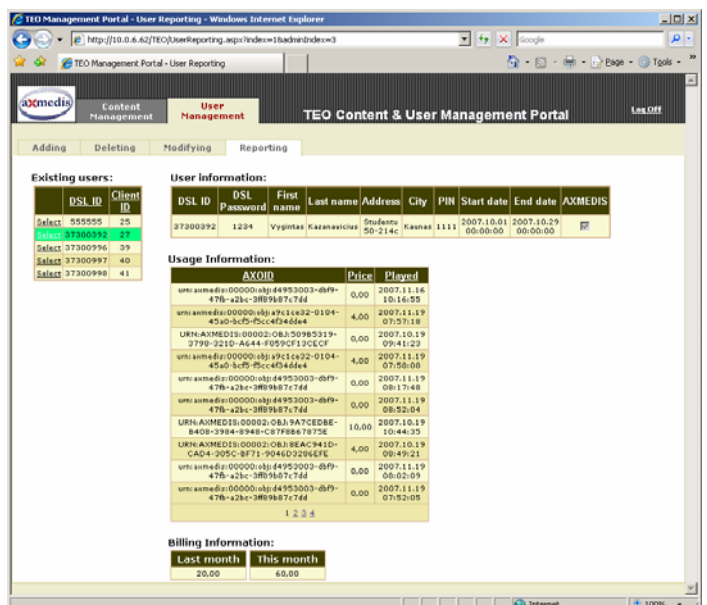



Key features of the TEO IPTV AXMEDIS system

The key features of TEO IPTV AXMEDIS solution are:

- AXMEDIS objects with MPEG 2 video content, specially processed for MPEG TS video with accompanying information;
- B2C distribution of video on demand (VOD) via IP network by means of MPEG-2 Transport Stream (TS) feeding an AXMEDIS compliant Set Top Box (STB) for viewing video on TV;
- Distribution and protection at signal protection level:
 - The transmitted video signal resource is encapsulated into MPEG-2 TS resource and scrambled using DVB-CSA algorithm. AXMEDIS AXOM is used for de-protecting video signal.
- Protection and DRM aspects:
 - At production (VRS Factory) level, using AXMEDIS Editor or AXCP automated production tool, with newly developed AXCP MPEG-TS Adaptation Plugin for scrambling MPEG-2 TS resource.
 - At Distributor (TEO) and end user level, upon trying to access protected AXMEDIS object, AXOM protection processor is executed to de-protect the object according to the issued license.
- License production:
 - Content provider creates mother licenses for distribution using its AXMEDIS Editor/DRM or AXCP tools or directly connecting with the AXMEDIS PMS Web Service.
 - End Users licenses are produced by TEO VOD access service using an AXCP Rule executed on the AXCP Scheduler and executor after receiving confirmation of payment. The issued license is sent to AXMEDIS PMS server.
 - License allows:
 - Free of charge view of trailers and pay-per-view for AXMEDIS objects.
 - Play, stop, pause and skip video stream from VOD server.
 - Other rights according to content type and business model
 - The AXMEDIS Objects are streamed from VOD server to the User's STB and played on AXSTB Player,
 - Registration of users and tools (AXSTB Player) as follows:
 - The end user is registered to TEO database upon subscription of IPTV service. TEO IPTV administrator checks AXMEDIS option in registration form and the user is registered to AXMEDIS AXCS deployed at TEO site.
 - When user buys STB hardware it is registered to AXCS automatically upon first usage.

Unique AXMEDIS benefits to IPTV service providers

Although technologies for IPTV video on demand content delivery and protection are advanced and available today, the focus of AXMEDIS solution is on showing the automatic nature of value chain relationship between video on demand content producer/wholesale distributor to IPTV service provider for end users. The key benefits are:

- The automatic or semi-automatic nature of workflow at production and distribution levels, thanks to AXMEDIS AXCP tools http://www.axmedis.org/documenti/view_documenti.php?doc_id=3624
- Transparent accounting and reporting of digital content consumed by value chain actors, thanks to AXMEDIS DRM tools http://www.axmedis.org/documenti/view_documenti.php?doc_id=3616
- The usage of a standard interoperable DRM with many other distribution channels and players see other technical notes and show cases, AXMEDIS is an extension of MPEG-21 standard DRM and format;
- The simple integration of distribution and production tools with the efficient P2P content distribution of AXMEDIS for B2B and B2C (in this case only the B2B part has been used) http://www.axmedis.org/documenti/view_documenti.php?doc_id=3612
- The connection with the AXMEDIS P2P network for accessing to the content to be distributed to IPTV
- The cross media content, when this type of content can be played according to the player capabilities. http://www.axmedis.org/documenti/view_documenti.php?doc_id=3634

Contact: Vytautas Valionis

TEO LT, AB; AXMEDIS ELTEO
Savanorių ave. 28
LT-03501 Vilnius, Lithuania
Tel: +370 5 236 7409
Fax: +370 5 212 6665
axmedisinfo@axmedis.org
vytautas.valionis@teo.lt