



Technical Note  
n.3903  
January 2009

**Automate your business processes, manage your content at lower costs:**

Multi-channel production and distribution: broadcasting, IP/Internet, WEB sites, P2P, mobile, PDA, IPTV, interactive TV and channels, etc.

Multi-channel experience for your customers

Exploit Video on Demand (VOD), and production on demand solutions

Control of P2P content sharing and distribution, involving your customers in distribution (super-distribution)

Involve your customers and final users in content production and social networking

Integrate interoperable DRM into your business (MPEG-21, OMA, etc.)

Exploit different business models and/or transactions on the same distribution channels: pay per play, monthly rate, preview, renting, advertising, etc.

Exploit interactivity with cross media models

Adopt advertising (customized and/or real time personalized advertising)



**AxMediaTech AXMEDIS Content Processing GRID**

The AXMEDIS content procesig is an open solution to reduce costs and increase efficiency for automated content management, media management, post-production, repurposing, processing, production, protection, and multichannel distribution. It is more than a CMS, DMS, etc. It is a Content processing scalable grid platform. AXCP allows an integrated content/media/channel management of pre- and post-production, following your business growth and integration demands.

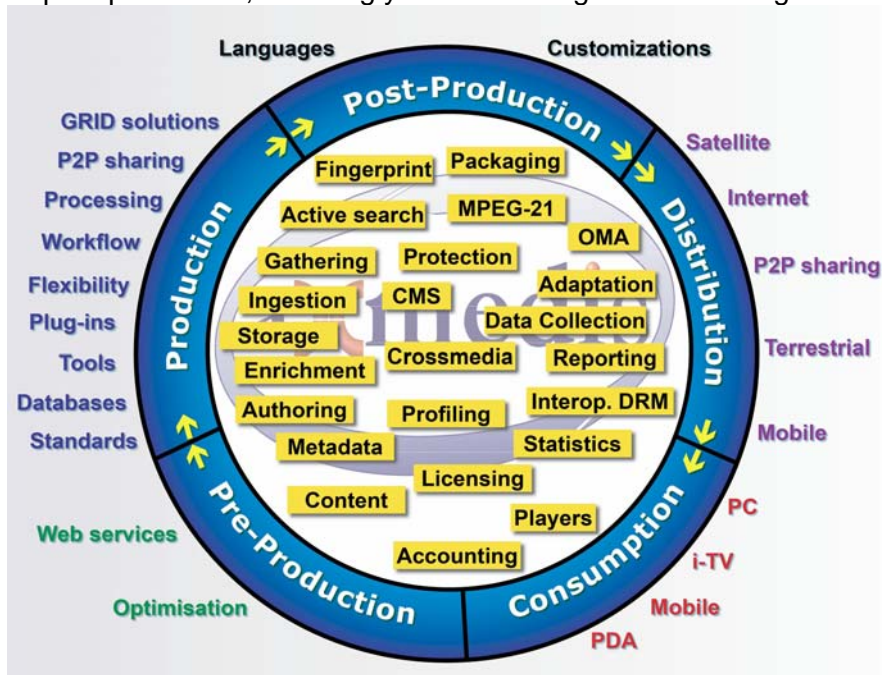

AXMEDIS allows automating solutions with scalable tools for managing single and multiple:

- o distribution channels: VOD, IPTV, WEBTV, DVB-T, web, P2P, FTP, WEBDAV, WebServices, etc.;
- o social network back office management, content processing and semantic/profile processing, see AXMEDIS XMF;
- o content formats: any video, any image, any document, any audio, SMIL, HTML, MPEG-21, MXF, NewsML, XML, XSLT, etc.;
- o final user devices: PC, STB/PVR, i-TV, Kiosks, PDA and mobiles;
- o user generated content processing and formatting;
- o interoperable DRM (digital rights management) models: MPEG-21 and OMA;
- o business models on the same and multiple distribution channels and content: pay per play, subscription, counting, renting, billing, etc., for B2B and B2C;
- o services for content production and/or distribution on demands;
- o content factories and processing areas via workflows (OpenFlow and BizTalk);
- o content management systems, CMSs, and/or archives.

**AXCP Main Technical capabilities**

The integrated management of channels, formats, devices, business models, services, etc. is performed by means of AXMEDIS Automated Factory Tools, also called **AXMEDIS Content Processing, AXCP**, tools. AXCP tools include solutions for the automated management, pre-/post-production processing and distributions of a large range of content formats, for automatically producing, processing, packaging, adapting, transcoding, formatting, and/or repurposing content, metadata, files, user registrations, profiles, licensing, etc.

AXMEDIS tools and solution allows the automation of the content management process, and the content production, distribution, and publication, The automated, AXCP, and manual authoring solutions are based on a Service Oriented



Architecture, SOA, to exploit legacy CMSs and archives, scheduling and automating the content production processes in the content factory and among geographically distributed factories, and workflows, etc. The user can easily formalize custom processes in AXMEDIS Javascript language and/or visual tools (the AXMEDIS javascript is compliant with javascript language).

AXMEDIS reduces the costs of content management, supports the whole value chain and makes real the convergence of media, and the interoperability of content enabling multi-channel distribution (e.g., mobile, satellite, kiosk, iTV, web, P2P, interactivity, etc), and provides a flexible and interoperable DRM, for both B2B and B2C across traditional and P2P distribution platforms. The following figure depicts an integrated AXCP solution for automated content processing and multichannel distribution.

AXCP solution is based on a scalable technology to satisfy the needs of small and large content producers, integrators, and distributors. The AXCP offers automated features and functionalities, supporting convenient integrated development tools to automate integrated activities of:

- content Ingestion and gathering, database management, crawling, indexing, archiving, gathering from OAI, etc.;
- query, download and publication on social networks: YouTube, Flickr, XMF (<http://xmf.axmedis.org>);
- content storage and retrieval, active querying;
- content processing, repurposing, adaptation, transmoding, transcoding for text, docs, images, audio, video, multimedia, XML, SMIL, HTML, styles, MXF, newsML, MPEG-4, MPEG-21, etc.;
- metadata repurposing, adaptation, transcoding, integration, enrichment, validation;
- content descriptors, extraction and comparison, fingerprint, MPEG-7, MPEG-21, etc.;
- content composition, formatting, layout, styling;
- communication with databases, FTP, HTTP, P2P and distribution servers via several protocols;
- content packaging: MPEG-21, MXF, OMA, newsML, ZIP, etc.;
- content protection via several algorithms;
- content DRM with MPEG-21 and OMA, with tracking and reporting rights exploitation;
- content licensing, licensing the production of licenses;
- content publication and distribution toward multiple channels;
- workflow management integration with BizTalk and OpenFlow;
- user management: registration, licensing, profiling, advertising.

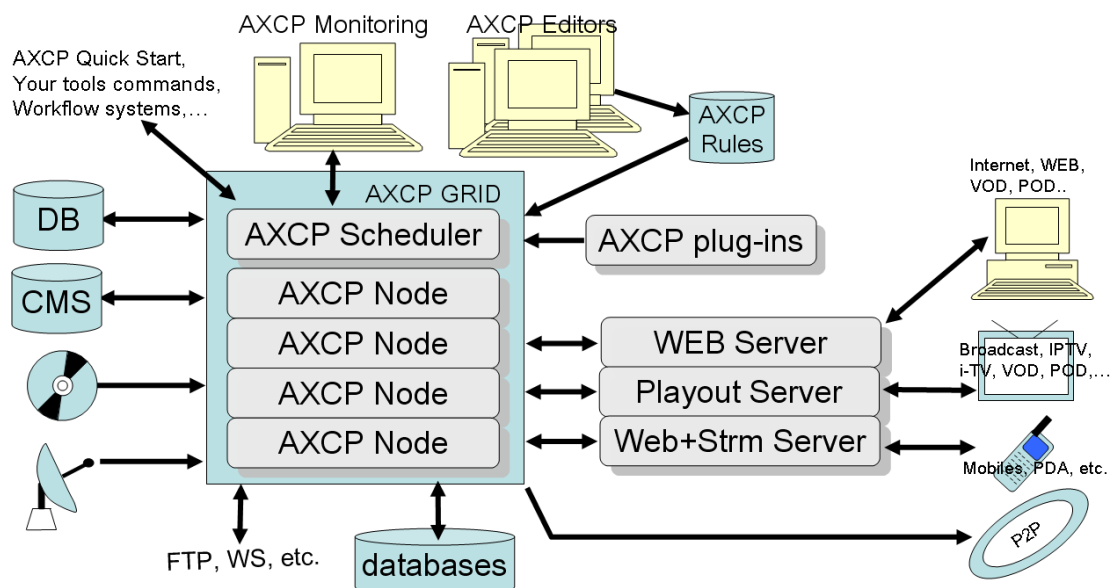

## AXXP Open Architecture and Solution

AXCP solution is based on AXCP Rules formalized in AXMEDIS JavaScript language to formalize jobs, processes and their deadlines, needs, etc. The AXCP solution is open and can be expanded and/or customized by:



- o creating and customizing AXCP Rules to be executed on AXCP Nodes;
- o activating Rules according to different policies such as: periodic, sporadic or on demand from third parties, external tools, web services, etc.;
- o customizing, realizing and installing additional AXMEDIS plug-ins to add new formats, encoders, decoders, adapters and converters, etc. The AXMEDIS Plug-in technology is open, well documented and supported by a development tool kit;
- o organizing AXCP GRID Nodes in a hierarchical manner. An AXCP Node may control one or more AXCP Schedulers which in turn may control other AXCP Nodes, etc.;
- o executing operating system processes, passing them parameters/files and getting eventual errors.

The AXCP architecture is Service Oriented Architecture (SOA); fully documented APIs for all the JavaScript functionalities, and WEB Services for accessing and controlling tools, and for distributing produced content towards your front-end distribution servers. This means that the Distribution Servers and solutions may very easily interact with the AXCP GRID via web services. All the services may lead to put in execution processes, to create licenses, content, etc.

### AXCP GRID solution main elements:

- **AXCP Rules can be:**

- executed on any AXCP Node, or single computer;
- used/parameterized for automating management activities;
- activated from Workflow Management System, from PHP, JSP, JAVA, Web Service clients, etc.;
- activated by AXCP Rules, detecting changes in the file system, local database, in the P2P, etc.;
- **AXCP Nodes** are controlled by the AXCP Scheduler, and can be
  - industrial computers or desktop computers in your offices delegating at the AXCP a part of their CPU along the day profile;
  - executed alone (with the AXCP standalone node) for executing sporadic AXCP Rules for ad-hoc processing and activation without demanding their allocation to the AXCP Scheduler;

- **AXCP Scheduler to allocate and manage AXCP Rules on GRID Nodes:**

- scheduling and balancing jobs/processes on AXCP Nodes according to the content production and processing needs in terms of time and resources: balancing nodes workloads, Deadline Monotonic, starting time, optimization;
- activating jobs as sporadic and periodic tasks, controlled by other tools and/or web services;
- monitoring progress of production processes and their status, etc.;

- **AXCP Rule Editor** is used to produce, debug, test and validate AXCP Rules to execute them on AXCP Nodes via AXCP Scheduler. As depicted in the first figure of this page. Assisted development with intellisense (word completion, suggestion, user and java script function list, etc.);

- **AXCP Visual Designer:** a visual tool for creating sequences of javascript segments and/or process components, and/or to define flows of rules that can be compounded and activated by the AXCP Scheduler with a click. The Visual Designer makes the programming of AXCP very simple and accessible to non expert users. Libraries of components can be created with the AXCP Editor;

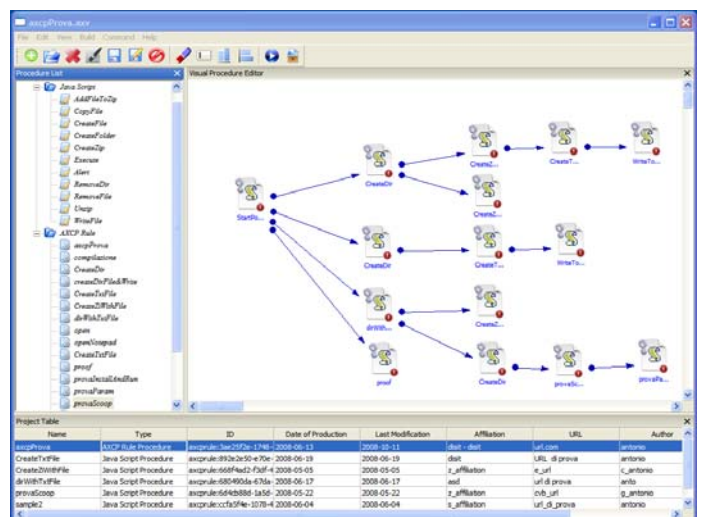
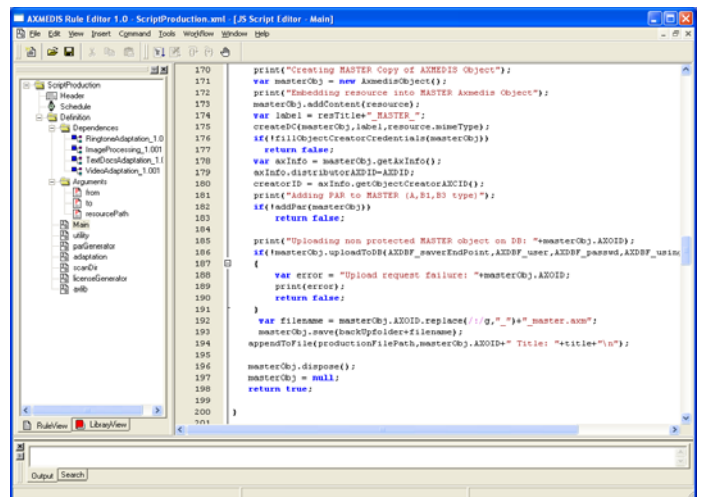

- **AXCP Quick Start** permits to activate AXCP Rules in a very simple manner by passing them parameters; for examples a collection of objects, a path, a database, a query, a list of files, etc., or just a click;
- **AXCP Standalone Node** allows putting in execution a single AXCP Rule from your applications and servers via a simple shell command. This solution is an easy way to access to the whole functionalities of the AXCP for executing an asynchronous process without calling the Web Service AXCP Scheduler.

As depicted on the right, the AXCP tools can be controlled at higher level by means of Workflow management systems such as OpenFlow and/or BizTalk.

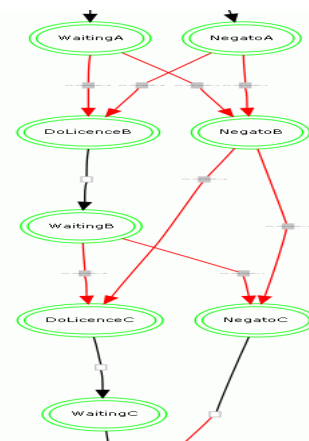

### AXCP Solution Reliability and Redundancy

The AXCP solution is reliable, scalable and fault tolerant. AXCP can run multiple copies of the same rules on different Nodes making possible the set up of fault tolerant solutions. AXCP nodes are capable to automatically reconnect to the AXCP Scheduler after a lack of connection. They can be located in the local network as well as remotely. The status of the AXCP scheduler is continuously saved allowing disaster recovery, thus to set up fault tolerant solutions and failover tolerant proof.

The AXCP solution is scalable in terms of number of AXCP Nodes and Schedulers. It may work on a single computer with all inside as well as on tens of industrial or desktop computers (that may put at disposal a part of their CPU power and file system). Each node may share file systems and access independently on the network and thus on databases. Thus, solutions with large numbers of distributed databases are possible to realize data and/or computational GRID solutions.

In addition, the AXCP can be used to set up hierarchical solutions, in which multiple AXCP Schedulers with their nodes are activated by other nodes and Rules.

### Technical Information

The AXCP solution is based in MS Windows XP. AXCP Scheduler and Nodes can be executed on high performance multi CPUs computers or single low resources computers depending on your needs in terms of performances. AXCP is provided as software or as hardware/software solution ready to be integrated in your company according to your needs. Training, integration and maintenance services are available.

### AXMEDIS Affiliation Programme

AXMEDIS has been adopted and is under trial by many industrial partners, who have expressed their appreciations, (see <http://www.axmedis.org/ibc2008/>, <http://www.axmediatech.com> ). AXMEDIS is open and allows to access source code, reports, technical support, training days, etc., by means of the affiliation program. It allows exploiting innovative research results with new tools and solutions.

### AXMEDIS Integrated Solutions

The AXCP solution can be used an independent tool, but it has also been designed to be used with:

- **AXMEDIS P2P Controlled Network**, for content distribution via P2P, B2B and B2C BitTorrent Technology with queries and catalogue, for protected content or not, automating content publication/distribution, controlling the P2P network, extracting statistical data and reports. AXMEDIS P2P network has P2P clients for PC and Mobiles.  
[http://www.axmedis.org/documenti/view\\_documenti.php?doc\\_id=3612](http://www.axmedis.org/documenti/view_documenti.php?doc_id=3612)
- **AXMEDIS DRM**, is a solution to adopt MPEG-21 DRM with other DRM solutions, includes servers and licensing tools and allows DRM, detection of attacks, black list management, collection of actions logs containing traces about the rights exploitation, tools for administrative management, etc.  
[http://www.axmedis.org/documenti/view\\_documenti.php?doc\\_id=3616](http://www.axmedis.org/documenti/view_documenti.php?doc_id=3616)
- **AXMEDIS Editor and players, tools for MPEG-21 and AXMEDIS authoring** (SMIL, HTML, MPEG-4, and of any kind of digital resource), DRM, licensing, protection, packaging, workflow, playing, etc. AXMEDIS authoring on Windows. AXMEDIS players for: MS Windows, Linux as core, Windows Mobile 5

and 6, and java mobiles, java for PC, STB/PVR/HDR, Media Centers, PDA, and mobiles. They can be customized as GUI and functionalities. Examples of customizations are available.

[http://www.axmedis.org/documenti/view\\_documenti.php?doc\\_id=3634](http://www.axmedis.org/documenti/view_documenti.php?doc_id=3634)

- **AXMEDIS COPOP**, content posting solution, to involve your final users, to collect their content and redistributed it for social networking, content enrichment and/or integrating it in your content business solutions.
- **AXMEDIS Cross Media Finder: an integrated portal for demonstrating AXMEDIS content and distribution:** <http://xmf.axmedis.org/>, for PC, PDA and mobile devices

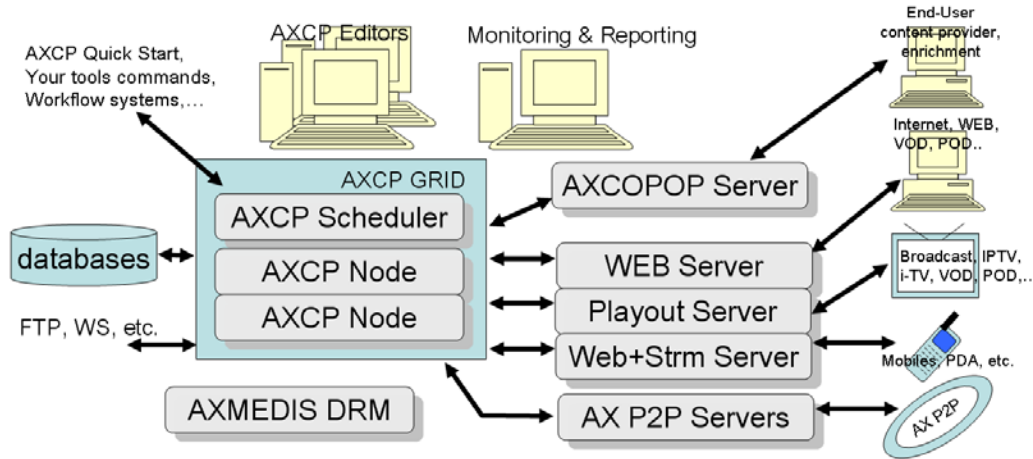

The above example describes an AXCP based solution in which AXMEDIS COPOP is used to collect content provided by final users. The content is distributed (after being processed, adapted, protected, etc.) in the traditional multichannel distribution as well as in the AXMEDIS P2P controlled network for PC and Mobiles.

The following example presents an AXCP solution for automated production, protection and distribution of content with DRM. This solution allows the reduction of costs for content post-production and management for DRMed distribution. In this case, the DRM technology can be MPEG-21 or OMA to distribute content according to several different business models (pay per play, monthly rate, etc.), setting up different rights (play, print, etc.), with different conditions (times of play, duration, etc.). The AXCP allows (i) producing content on demand on the basis of final user profiles (device, network, etc.); (ii) producing licenses on demand for pay per play and new subscriptions; and (iii) managing black lists of terminals and/or users.

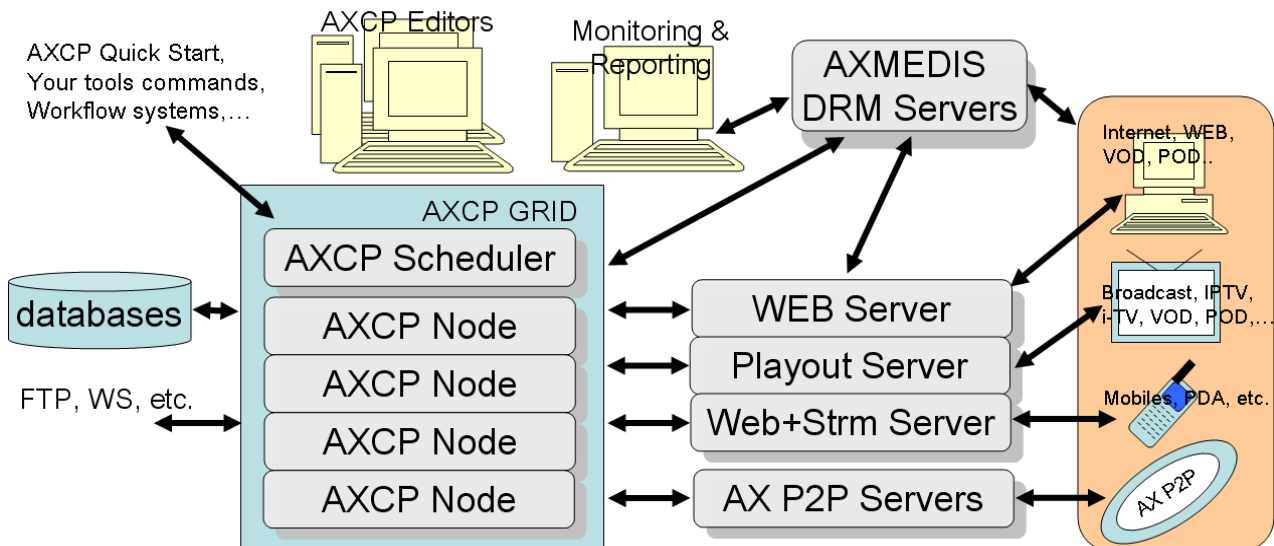



## AXCP Rules Functionalities

The language is an evolution of the standard JavaScript language. The following functionalities have been added by adding new operators and/or new libraries accessible as native Javascript functionalities or by means of AXMEDIS Plug ins. AXMEDIS plug ins have been mainly used for adding transcoding and content processing capabilities. The addition of new functionalities according to your needed is possible by adding new plug ins, or by creating AXMEDIS Javascript functionalities.

### Firing and control activities

- Activation via AXCP scheduler web service
- Activation via AXCP Quick Start tool
- Activation via Workflow tools
- Activation via your Applications, Java, C++, PHP, etc.
- Activation via detection of files changing
- Cross activation of a rule via another rule
- Time periodic activation
- Time sporadic activation

### Content and metadata access, ingestion and gathering from

- CMSs and databases:
  - ORACLE, XML databases, Tamino, eXact
  - Lobster®, MySQL, MSSQL, HP DMP, ODBC, ..
- OAI, Open Archive based accesses;
- operating systems files:
  - MS Windows
- protocols:
  - SQL, Web Services, FTP, HTTP,
  - SFTP, HTTPS
  - WebDAV, SMB, Gopher, NNTP
- formats:
  - MXF, NewsML, IMS SCORM, MPEG-21, etc.
- Focuseek crawling tool:
  - file system DB2, Oracle, MySQL, ODBC,
  - IMAP4, POP3, WebDAV, RSS, etc.

### Content and metadata management and retrieval

- from AXMEDIS database (MPEG-21 database) or from others
- actualizing the queries into the scripts, definition of active/dynamic queries
- from P2P AXMEDIS network
- multi-archive content crawling, extraction and aggregation with metadata
- any databases via HTTP and/or ODBC, etc.
- integration with HP DMP, Digital Media Platform
- integration with GIUNTI mobile distribution platform
- Integration with TISCALI Media Club VOD distribution platform
- Integration with other solutions for content distribution see [WWW.AXMEDIS.ORG/IBC2007](http://WWW.AXMEDIS.ORG/IBC2007)

### Metadata models and processing

- metadata models and extensions:
  - Dublin Core full set
  - complex metadata such as: EAD, DC

- multiple Unique IDs and descriptors: UUID, ISBN, ISRC, ISAN, ISMN, etc., your IDs
- business metadata such as: AXInfo
- Potentially Available Rights, PAR, Licensing information in MPEG-21 REL
- any custom metadata
- Workflow information
- Protection information
- Content descriptors as Metadata
- MPEG-7 descriptors
- Content fingerprint for recognition and monitoring distribution channels
- metadata manipulation and processing:
  - mapping via XSLT (production of mapping with specific editor)
  - filtering via XSLT
  - processing via XSLT

### Content Processing for audio videos, document, images, and any files:

- digital resources adaptation and transcoding
- extraction of descriptors and/or fingerprints
- watermarking
- indexing
- classification
- summarization
- filtering
- repurposing
- recognition
- search and retrieval
- MIME type description and access of files

### Text/Document processing, adaptation and transcoding:

- text processing with regular expressions and other techniques
- text language detection
- text transcoding by format:
  - PDF-TXT, HTML, PS, RTF,
  - MS-Word, Plain text,
  - Etc.
- text keywords Multilanguage:
  - Extraction from comparison (corpus based)
  - Extraction from semantic analysis
- text fingerprint:
  - Extraction
  - Plagiarism detection

### Audio Processing, adaptation and transcoding:

- Audio transcoding:
  - WAV, WMA, MPEG, VORBIS, AC3, DV,
  - MACE, ADPCM, AAC, real audio, AIFF,
  - PARIS, NIST, SVX, IRCAM, W64, SD2, MP3,
  - etc.
- RingTones:
  - Operations of: resample, clip, etc.
- Audio descriptors:



- o Low level descriptors extractor: waveform, spectrum, centroid, MFE, MFCC, ZCR, Spectral Flatness, onset and offsets, etc.
- o High level descriptors extractor: audio segmentation, music genre, rhythm, silence detection, spoken/music content, noise
- Audio fingerprint:
  - o M2Any fingerprint algorithm and recognition
  - o Philips fingerprint algorithms
  - o AudiID fingerprint algorithm
  - o extractors and comparison of fingerprints
  - o detection of plagiarism

### Video Processing, adaptation and transcoding:

- Video transcoding
  - o FFMPEG and other libraries
  - o MPEG-1, MPEG-2, MPEG-4, VC1, H.261, RealVideo 1.0, RealVideo 2.0, MJPEG,
  - o RAW, lossless MJPEG, FLV,
  - o H.263, WMV, ASF, ASUS, DV, YUV, ASV1,
  - o ASV2, SVQ1, SVQ2, AVI, FLAC, DAUD, AVS,
  - o H.264, VP3, FFW, Flash, VCR1, VCR2,
  - o CLJR, Apple, DXA, THP, AASC, DVD, 3GPP, etc.
- Video descriptors MPEG-7
  - o GoF/GoP color
  - o Dominant color
  - o Homogeneous Texture
  - o Color Structure
- Video fingerprint:
  - o extractors and comparison of fingerprints
  - o detection of plagiarism

### Image Processing, adaptation and transcoding:

- Image conversions of more than 100 different formats:
  - o JPG, GIF, PNG, BMP, TIF, SVG, PS,
  - o PDF, MPEG, PCX, PGH, PICT, PIX,
  - o RGB, TGA, TXT,
  - o WMF, XPM, YUV, YCbCr, YcbCrA, etc.
- text to image conversion
- Image processing algorithms:
  - o Contrast, edge, blur, media, mirror, equalize,
  - o magnify, resize, roll, scale, shade,
  - o negate, noise, filtering, rotate, past, spread,
  - o extract, overlap, replace, shear, etc.

### Digital File Fingerprint and recognition

- Estimation of fingerprint of digital files:
  - o MD5, SHA-1, base64, ascii-bin, etc.
- Recognition of fingerprint by similarity

### Content Composition Presentation and Interactive models

- creation of cross media and multimedia content combining raw assets such as text, images, audio, video, animation, metadata, descriptors, licenses, and other

- multimedia objects in formats
  - o MPEG-4
  - o HTML
  - o SMIL
  - o MPEG-21 (supported by AXMEDIS Editor and players for MPEG-21)
  - o NewsML (load)
  - o MXF (load and save)

### Multimedia and cross media adaptation/processing

- Create MPEG-4
- Create MPEG-4 SMR (Symbolic Music representation)
- Audio visual processing:
  - o concatenation, delay, extract
- MPEG-4 remove tracks
- conversions:
  - o MPEG-4 to 3gp
  - o MPEG-4 to AVI
  - o MPEG-4 to ISMA
  - o SMIL to HTML

### General Information Processing of:

- Load/import, production and saving of XML files for commands and/or metadata
  - o based on E4X model
- Load/save any file from/to the operating system, server, FTP etc.
- Production of custom, template and/or behavior-based, HTML pages
- Production of custom, template and/or behavior-based, SMIL scenes
- Processing XSLT with XALAN

### Distribution and control of P2P network

- Monitoring of P2P nodes and network status
- Automatic publication of content into the P2P network
- Automatic download of content from the P2P network
- Control the seeding capabilities
- Accessing to reporting and statistics
- Remote control of P2P network
- Removing obsolete content from P2P network

### Integration with Social Networks

- YouTube: query, download and upload, processing
- Flickr: query, download and upload, processing
- XMF social network tool to make your social network: query, download and upload, processing, <http://xmf.axmedis.org>

### Communication Capabilities:

- Accessing to a large range of databases
- Accessing to Web Services; dynamic client generator based on WSDL
- Accessing FTP/SFTP sites, GET/PUT, etc.
- Accessing operating system, activating shells, etc.
- Sending commands HTTP, HTTPS
- Sending Mails, with attachments and/or HTML
- Sending SMS
- Creating reports in:

- TXT, CSV, HTML, XML, XHTML, ...

## Workflow management Production Process

- integration of the AXCP tools with OpenFlow and BizTalk Workflow Management systems
  - receive commands
  - activate scripts passing parameters
  - returning values and results
- definition of full customized solution for workflow management
- WEB based interfaces for creating GUI to control AXCP GRID processing
- WEB based interface for monitoring AXCP reports and results
- Collaborative Workflow solutions

## Content Packages, Media Containers and DRM

- MPEG-21 file read and production, with any digital resource inside, from other MPEG-21 to HTML, SMIL, groups of files and related resources
- MPEG-21 to keep joined your metadata and digital resources as well as to package and delivering them as unique chunks of information with DRM
- OMA files production
- IMS SCORM ingestion
- ZIP ingestion and production
- production of MPEG-2 TS streams
- RSS ingestion and production
- ATOM ingestion and production (in progress)
- MXF ingestion and production
- newsML ingestion and production

## WEBtv, IPTV

- Acquisition and processing of EGP, XML EPG for DVB-T, DVB-S, ..
- Integration from Sky EPG server

## Content Formatting

- structuring and styling content elements by means of SMIL based templates
- applying style-sheets to define the usage interface (format, layout) of the whole collection of content elements and the interested content usage paradigms
- Genetic Algorithms for best time fitting, etc.

## Profiling and their management

- Reading and manipulating:
  - user profiles
  - network profiles
  - context profiles
  - device profiles
- Recommendations, favourites, voting, etc.
- Reasoning based on Clustering: K-Means and other algorithms
- Reasoning based on profile distances.

## Content Adaptation Process

- Digital Item Adaptation (DIA) based on MPEG-21 DIA

- Decision taking engine for DIA based on the above mentioned profiles.
  - Rule based
  - Ontology and inferential engine based
- Scripting capabilities for expanding DIA and decision taking engine

## Content Protection and DRM

- Content registration (unique IDs) and verification
- Content and digital files signature
- Content fingerprints and watermarks
- Protection of digital resources and objects with MPEG-21 IPMP, OMA
- protection/encryption:
  - AES, DES, 3-DES, blowfish, Cipher, CAST
- Tracking exploited rights and reporting actions performed to the content owner, distributors, collecting societies, etc.
- Manipulating MPEG-21 protected objects according to AXCP Node license
- Open to integrate other DRM solutions

## Content Licensing and DRM

- generating license from license model and additional information, storing licenses, and posting to license server automatically
- supporting transcoding/translating licenses (MPEG-21 REL, OMA ODLR);
- posting licenses on license server
- verification of licenses
- resolving nationality from IPs

## Content Publication and Distribution

- supporting distribution towards multiple channels, for one or more: Internet, satellite, mobile, P2P distributions
- producing, monitoring and editing programmes and schedules
- controlling P2P AXMEDIS network in downloading and publishing reducing the seeding time to zero
- connecting other AXMEDIS Factories of content integrators, producers, and distributors
- posting content on the EUTELSAT Carousel for broadcasting.



### Contact:

[info@axmediatech.com](mailto:info@axmediatech.com)

<http://www.axmediatech.com>